



PLUGS - P

ISO fittings

HHP - M

Hex Head Plug
Male thread : Metric (M) - ISO 261

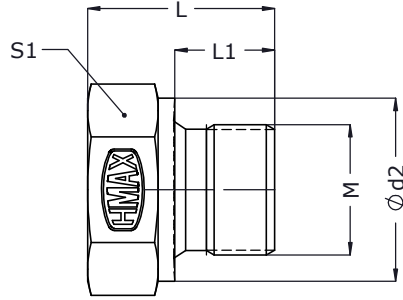

2D Body

Working Pressure (bar)	'M' Male thread Metric	$\phi d2$	i	L	S1	Part code	Item no_
630	M10 X 1.0	14	8	16	14	HHPM10	1888
630	M12 X 1.5	17	12	20	17	HHPM12	1889
630	M14 X 1.5	19	12	20	19	HHPM14	1890
630	M16 X 1.5	21	12	22	22	HHPM16	249
630	M18 X 1.5	23	12	23	24	HHPM18	1891
630	M20 X 1.5	25	14	25	27	HHPM20	1892
400	M22 X 1.5	27	14	26	27	HHPM22	1893
160	M26 X 1.5	31	16	29	32	HHPM26	1894
400	M27 X 2.0	32	16	29	32	HHPM27	1895
400	M33 X 2.0	39	16	34	41	HHPM33	1896
250	M42 X 2.0	49	16	36	50	HHPM42	1897
250	M48 X 2.0	55	16	37	55	HHPM48	1898

HHP - M - ES

Hex Head Plug with Elastomeric seal(ISO 9974-4)
Male thread : Metric (M) - ISO 261

For, Elastomeric Seal details Refer page No_ 82.

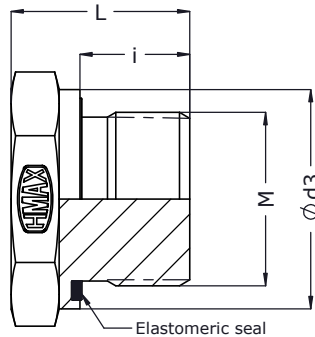

2D Body

Working Pressure (bar)	'M' Male thread Metric	$\phi d3$	i	L	S1	Tightening Torque N-m	Part code	Item no_
400	M10 X 1.0	14	8	12.3	5	20	SHPM10ES	1923
400	M12 X 1.5	17	12	17.3	6	30	SHPM12ES	1924
400	M14 X 1.5	19	12	17.3	6	45	SHPM14ES	297
400	M16 X 1.5	22	12	17.3	8	60	SHPM16ES	252
400	M18 X 1.5	24	12	17.3	8	80	SHPM18ES	1925
400	M20 X 1.5	26	14	19.3	10	100	SHPM20ES	253
400	M22 X 1.5	27	14	19.3	10	80	SHPM22ES	298
160	M26 X 1.5	32	16	21.3	12	120	SHPM26ES	1926
400	M27 X 2.0	32	16	21.3	12	135	SHPM27ES	1927
400	M33 X 2.0	40	16	22.8	17	225	SHPM33ES	1928
250	M42 X 2.0	50	16	22.8	22	360	SHPM42ES	1929
250	M48 X 2.0	55	16	22.8	24	400	SHPM48ES	1930