

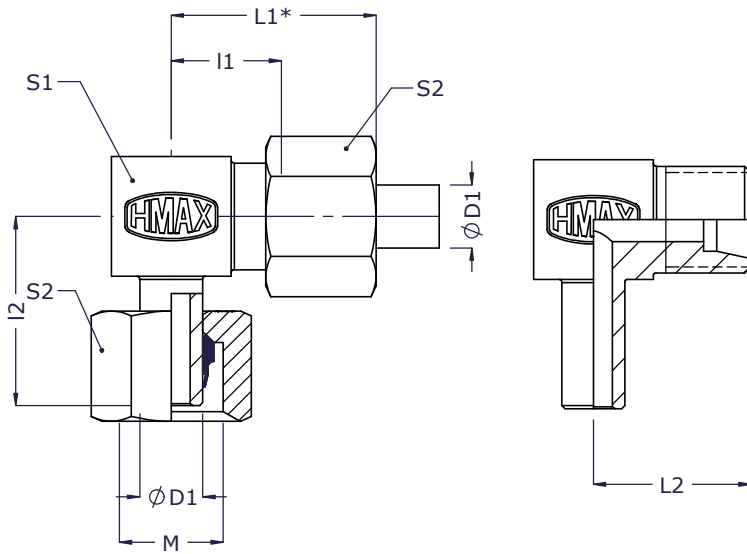

Swivel Elbow Couplings - SE (BAR - STOCK)

ISO fittings

Metric Tube end as per ISO 8434



2D Assembly

2D Body

Series	Tube od ØD1	M Metric thread	l1	l2	L1*	L2	S1	S2	Assembly		Body
									Part code	Item no_	Item no_
Light (L) 250 bar	6	M12x1.5	12.0	26.0	27.5	19	12	14	SE6L-F	779	414
	8	M14x1.5	14.0	27.5	29.0	21	14	17	SE8L-F	780	2077
	10	M16x1.5	15.0	29.0	30.5	22	17	19	SE10L-F	781	2078
	12	M18x1.5	17.0	29.5	32.0	24	19	22	SE12L-F	782	2079
	15	M22x1.5	21.0	32.5	37.0	28	22	27	SE15L-F	783	2080
160 bar	18	M26x1.5	23.5	35.5	40.5	31	27	32	SE18L-F	784	2081
	22	M30x2.0	27.5	38.5	44.5	35	30	36	SE22L-F	785	2082
100 bar	28	M36x2.0	30.5	43.0	48.5	38	36	41	SE28L-F	786	2083
	35	M45x2.0	34.5	51.0	57.5	45	46	50	SE35L-F	787	2084
	42	M52x2.0	40.0	56.0	63.5	51	55	60	SE42L-F	788	2085
Heavy (S) 630 bar	6	M14x1.5	16.0	27.0	31.5	23	14	17	SE6S-F	789	2086
	8	M16x1.5	17.0	27.5	32.0	24	17	19	SE8S-F	790	2087
	10	M18x1.5	17.5	30.0	34.5	25	19	22	SE10S-F	791	2088
	12	M20x1.5	21.5	31.0	38.0	29	22	24	SE12S-F	792	2089
400 bar	16	M24x1.5	24.5	36.5	43.5	33	24	30	SE16S-F	793	2090
	20	M30x2.0	26.5	44.5	49.0	37	30	36	SE20S-F	794	2091
	25	M36x2.0	30.0	50.0	55.0	42	36	46	SE25S-F	795	2092
250 bar	30	M42x2.0	35.5	55.0	63.5	49	46	50	SE30S-F	796	2093
	38	M52x2.0	41.0	63.0	72.5	57	55	60	SE38S-F	797	2094

* Dimensions given are approx figures with tightened nut.



Swivel Elbow Couplings - SE (FORGED)

ISO fittings

Metric Tube end as per ISO 8434

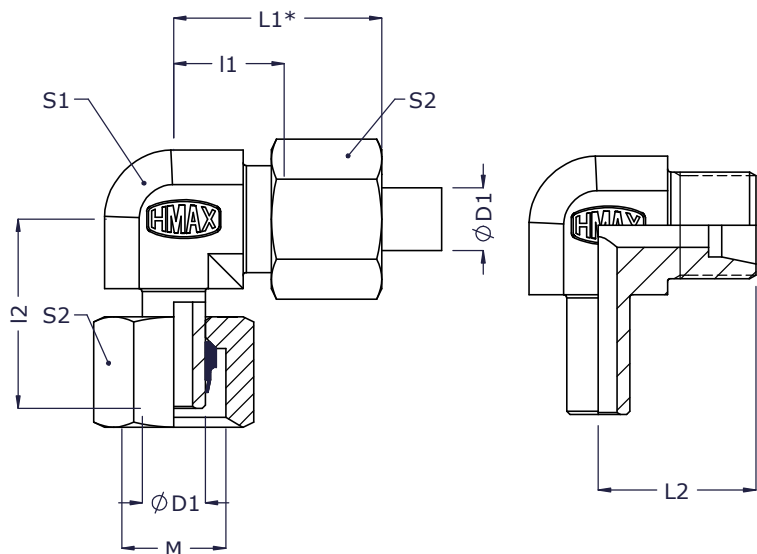

2D Assembly

2D Body

Series	Tube od ØD1	M Metric thread	l1	l2	L1*	L2	S1	S2	Assembly		Body
									Part code	Item no_	Item no_
Light (L) 250 bar	6	M12x1.5	12.0	26.0	27.5	19	12	14	SE6L	798	147
	8	M14x1.5	14.0	27.5	29.0	21	14	17	SE8L	799	393
	10	M16x1.5	15.0	29.0	30.5	22	17	19	SE10L	800	1157
	12	M18x1.5	17.0	29.5	32.0	24	19	22	SE12L	801	1158
	15	M22x1.5	21.0	32.5	37.0	28	22	27	SE15L	802	1159
160 bar	18	M26x1.5	23.5	35.5	40.5	31	27	32	SE18L	803	1160
	22	M30x2.0	27.5	38.5	44.5	35	30	36	SE22L	804	1162
100 bar	28	M36x2.0	30.5	43.0	48.5	38	36	41	SE28L	805	701
	35	M45x2.0	34.5	51.0	57.5	45	46	50	SE35L	806	1155
	42	M52x2.0	40.0	56.0	63.5	51	55	60	SE42L	807	1163
Heavy (S) 360 bar	6	M14x1.5	16.0	27.0	31.5	23	14	17	SE6S	808	2095
	8	M16x1.5	17.0	27.5	32.0	24	17	19	SE8S	809	601
	10	M18x1.5	17.5	30.0	34.5	25	19	22	SE10S	810	1164
	12	M20x1.5	21.5	31.0	38.0	29	22	24	SE12S	811	1166
400 bar	16	M24x1.5	24.5	36.5	43.5	33	24	30	SE16S	812	1167
	20	M30x2.0	26.5	44.5	49.0	37	30	36	SE20S	813	1168
	25	M36x2.0	30.0	50.0	55.0	42	36	46	SE25S	814	1169
250 bar	30	M42x2.0	35.5	55.0	63.5	49	46	50	SE30S	815	694
	38	M52x2.0	41.0	63.0	72.5	57	55	60	SE38S	816	1022

* Dimensions given are approx figures with tightened nut.